

MC4181-4, -8  
W/MC-DPT-012 DR  
-014 INSTALLED

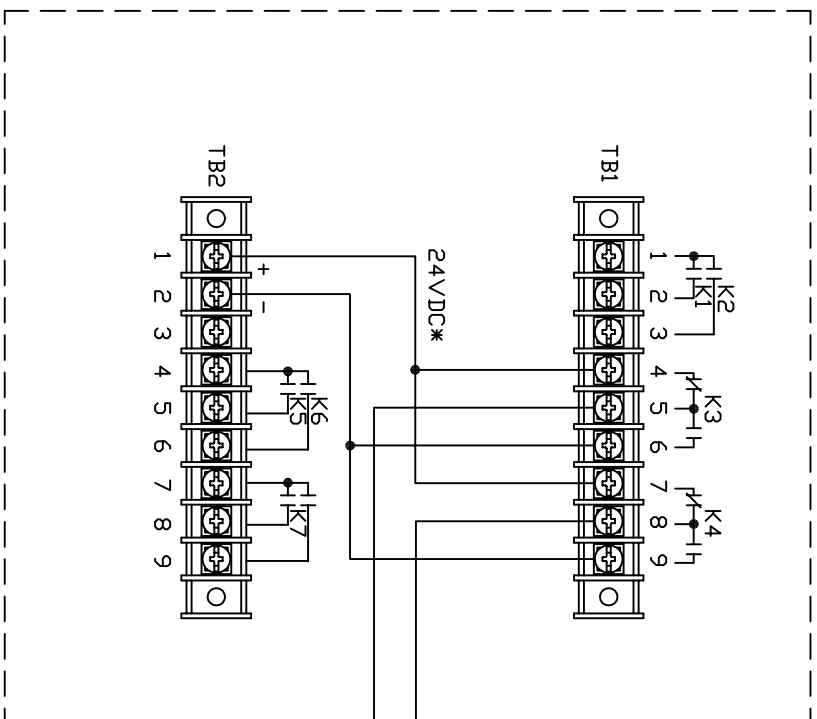

USE REQUIRED WIRE SIZE  
DETERMINED BY NUMBER OF  
CLOCKS AND THE DISTANCE  
TD EACH CLOCK LOCATION

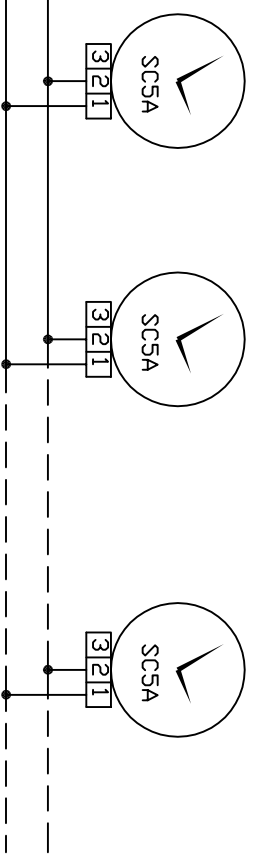

SPECIFICATIONS:

\* MC4181-4, W/MC-DPT-012

MODE 8  
BUILT-IN 24VDC, 2A POWER SUPPLY  
POWER SUPPLY WILL HANDLE UP TO 200 SLAVE CLOCKS  
TYPICAL SLAVE CLOCK: SC5A

\* MC4181-4 W/MC-DPT-014

MODE 8  
BUILT-IN 24VDC, 75A POWER SUPPLY  
POWER SUPPLY WILL HANDLE UP TO 75 SLAVE CLOCKS  
TYPICAL SLAVE CLOCK: SC5A

WWW.ATS-USA.COM

APPROVALS	DATE
DRAWN BY DTI	6-29-01
CHECKED BY	
APPROVED BY	

VCAD LTV\ATS DWGS\AP MC\41\_81\

P.O. BOX 5705  
SHREVEPORT, LA  
71135

PROJECT	SCALE	NTS
MC4181-4, -8	JOB #	
W/MC-DPT-012 DR -014	SHEET #	
WIRING DIAGRAM	REVISION	
DESCRIPTION	FILENAME: OPT14W/D1	DRAWING #
WIRING DIAGRAM		